

HunterDouglas 

Installation • Operation • Care

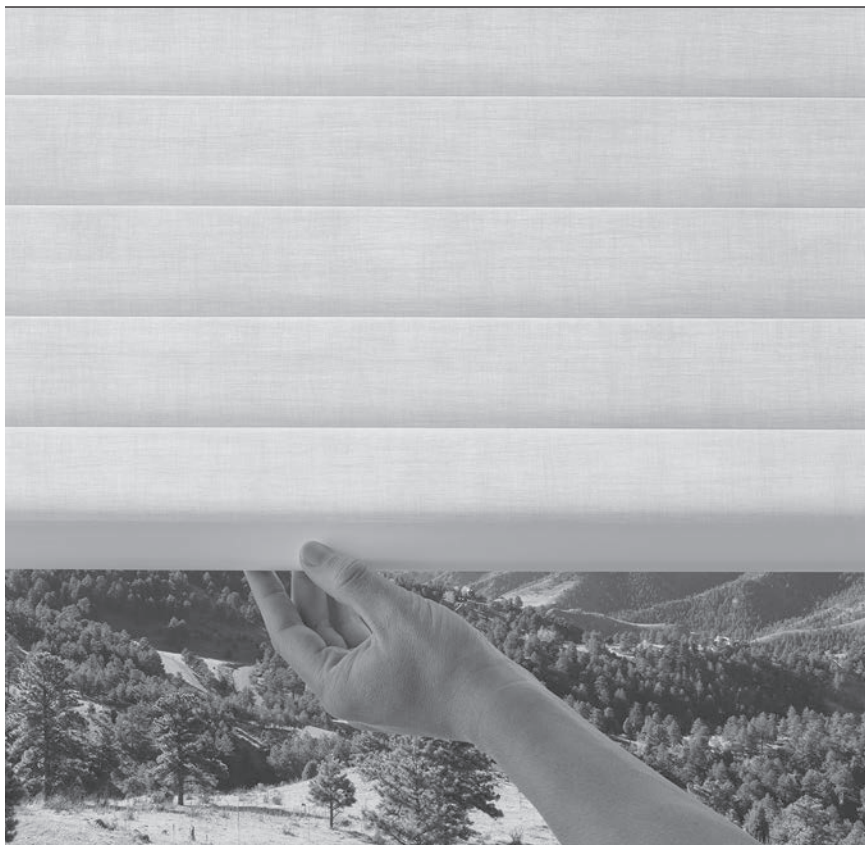

Sonnette™
Cellular Roller Shades

LiteRise® Operating System

CONTENTS

GETTING STARTED:

Product View.....	1
Tools and Fasteners Needed	2

INSTALLATION:

Installation Overview	3
Mount the Installation Brackets — Inside Mount.....	4
Mount the Installation Brackets — Outside Mount	6
Install the Shade.....	8

OPERATION:

Operate the Shade	10
Troubleshooting	11

CARE:

Removing the Shade	14
Cleaning Procedures	14

WARRANTY..... Back Cover

Questions?

Call Hunter Douglas Consumer Support at **1-888-501-8364**.

Product View

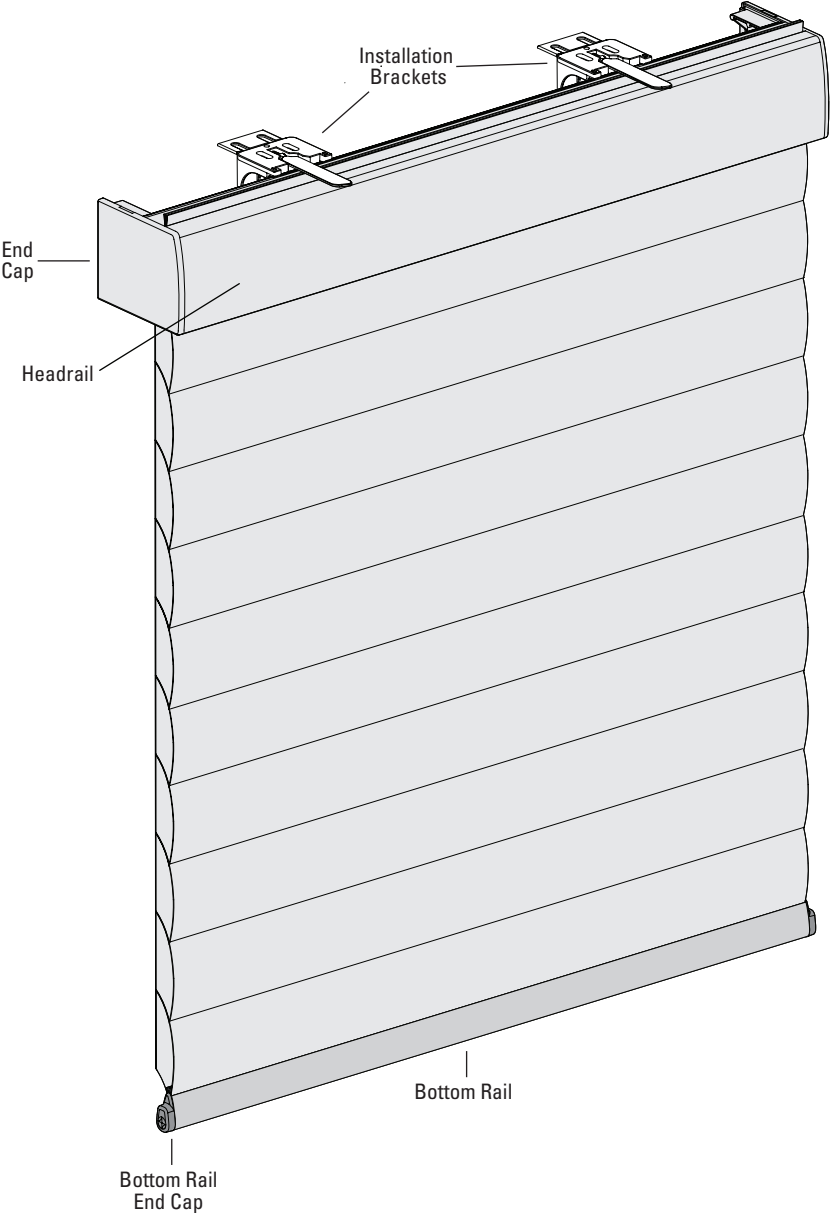

GETTING STARTED

Thank you for purchasing Hunter Douglas Sonnette™ cellular roller shades. With proper installation, operation, and care, your new shades will provide years of beauty and performance.

Please thoroughly review this instruction booklet and the enclosed packing list before beginning the installation.

Tools and Fasteners Needed

- $\frac{3}{16}$ " Allen wrench
- Flat blade and Phillips screwdrivers
- Level (laser level is recommended)
- Measuring tape and pencil
- Power drill, $\frac{3}{32}$ " drill bit, and $\frac{1}{4}$ " hex driver (or socket wrench with $\frac{1}{4}$ " hex socket)
- Scissors (heavy-duty)

In addition, you will need fasteners designed to work with your specific mounting surface(s).

- **#6 Hex Head Screws (Provided).** Two 1½" screws are provided per installation bracket.
- **Longer #6 Hex Head Screws (Not Provided).** If using spacer blocks, use #6 screws long enough for a secure attachment.
- **Speed Nuts and Screws (Provided).** Extension brackets come with screws and speed nuts.
- **Drywall Anchors (Not Provided).** Use drywall anchors when mounting into drywall.



#6 x 1½"
Hex Head Screw
(Provided)



Longer #6 Hex Head Screw
for Use with Spacer Blocks
(Not Provided)



Speed Nut
and Screw
(Provided with Each
Extension Bracket)

Installation Overview

- Your order will include the correct number of installation brackets for your shade width, as shown in the table below.
- Shade orders may also include spacer blocks or extension brackets, if they were specified for added clearance.

Installation Bracket

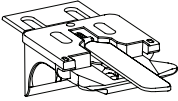

Shade Width	Brackets
20" – 36"	2
36 1/8" – 72"	3

For Added Clearance

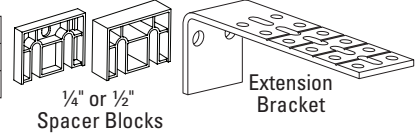

1/4" or 1/2" Spacer Blocks

Extension Bracket

Mounting Types and Window Terminology

If the installation brackets are mounted correctly, the rest of the installation process follows easily. To prepare for this important first step, review the mounting types and basic window terminology illustrated below.

Molding

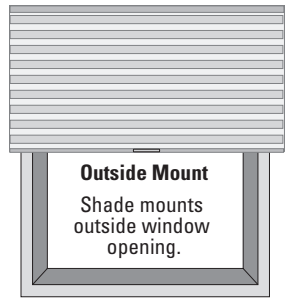
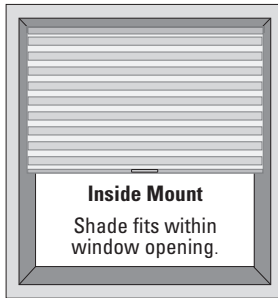
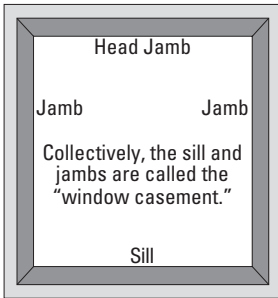

- Refer to the appropriate page below based on your order:
 - **Inside Mount — Page 4**
 - **Outside Mount — Page 6**

INSTALLATION

Mount the Installation Brackets — Inside Mount

Prepare the Installation Brackets

- Use pliers or heavy duty scissors to remove the top tabs on the installation brackets.

NOTE: Save these tabs once removed. They may be used as shims, if necessary.

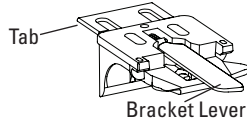

Mount the Installation Brackets

- Mark 2" to 3" from each jamb for bracket location.
 - If more than two installation brackets came with your order, space additional bracket(s) evenly between the two end brackets and mark their location. Mount into wood whenever possible.

NOTE: Before the headrail is installed the bracket levers need to be fully to the left and once the headrail is properly in place, levers click to the right.

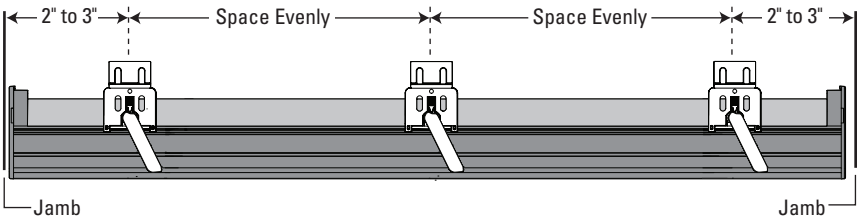

- Center the brackets on your marks and mark the location of the screw holes.

- The minimum casement depth required for installation brackets is 1".
- The minimum casement depth required for a fully recessed mount is $3\frac{3}{16}$ ".

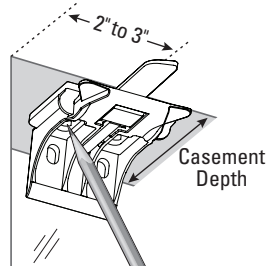

- Use a level to check that the mounting surface is level. Shim the brackets, if necessary (use the top tab that was removed from the brackets).

- Drill the screw holes using a $\frac{3}{32}$ " drill bit.

CAUTION: Use drywall anchors when mounting into drywall.

- Attach the installation brackets using the screws provided.

IMPORTANT: Do not overtighten the screws. Check to ensure the bracket lever can be moved easily side to side. If not, loosen the screws in one-eighth turn increments until the lever can be moved easily.

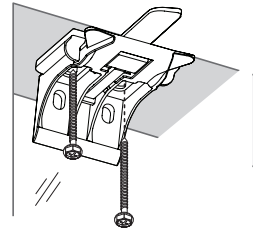

IMPORTANT: The front edges of the installation brackets must be level and aligned to each other.

Proceed to "Install the Shade" on page 8.

INSTALLATION

Mount the Installation Brackets — Outside Mount

Prepare the Installation Brackets

- Use pliers or heavy duty scissors to remove the top tabs on the installation brackets.

NOTE: Save these tabs once removed. They may be used as shims, if necessary.

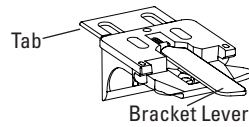

Mount the Installation Brackets

- Center the headrail over the window opening at the desired height. Use a pencil to lightly mark each end of the headrail.
 - Alternatively, measure the width of the headrail and use that width to mark the headrail end points over the window opening.
- Mark 2" to 3" from each end of the headrail.
 - If more than two installation brackets came with your order, space additional bracket(s) evenly between the two end brackets and mark their location. Mount into wood whenever possible.

NOTE: Before the headrail is installed the bracket levers need to be fully to the left and once the headrail is properly in place, levers click to the right.

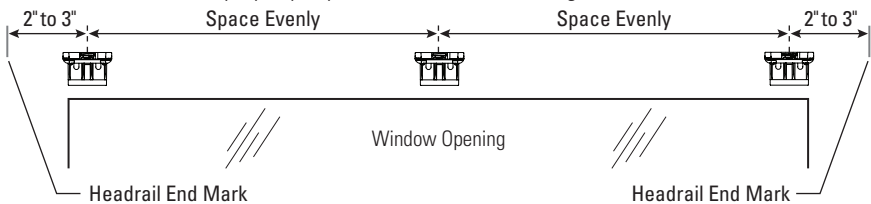

- Center the installation brackets or extension brackets on your marks and mark where to drill the screw holes.
 - A minimum 1 1/8" flat vertical surface is required for the installation brackets. Extension brackets require 1 1/4".
 - The top of the installation brackets or extension brackets should be at the desired height. The brackets should be level and aligned.

CAUTION: The rear of the brackets must be flush against a flat mounting surface. Do not mount brackets on curved molding.

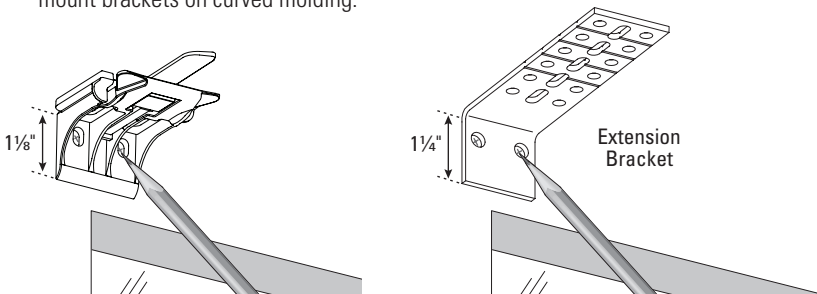

- Drill the screw holes using a $\frac{3}{32}$ " drill bit.

CAUTION: Use drywall anchors when mounting into drywall.

- Attach the installation or extension brackets using the screws provided.

IMPORTANT: The top of the installation brackets or extension brackets must be level with their front edges aligned.

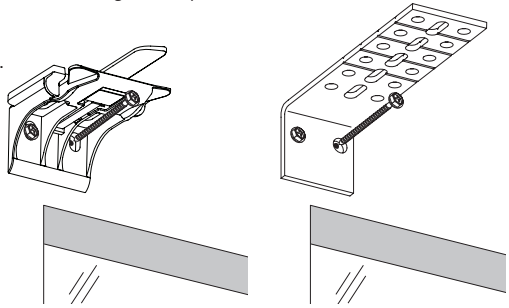

- If using spacer blocks for added clearance, attach the spacer block(s) and installation bracket to a flat vertical mounting surface with #6 screws long enough for a secure installation.

➤ The top of the spacer blocks should be at the desired shade height.

IMPORTANT: Do not add more than $1\frac{1}{2}$ " of clearance using spacer blocks.

IMPORTANT: The tops of the installation brackets must be level with the front edges aligned.

CAUTION: Use drywall anchors when mounting into drywall.

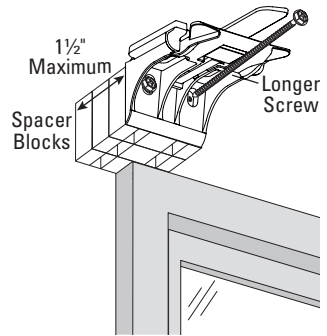

- If using extension brackets, attach an installation bracket to the underside of each extension bracket using the speed nuts and screws provided.

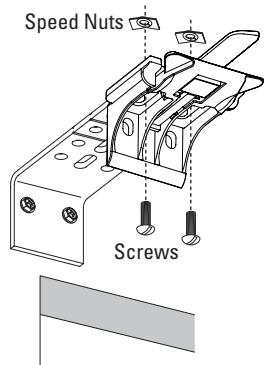

Proceed to "Install the Shade" on page 8.

INSTALLATION

Install the Shade

- Ensure that each lever is pushed to the left side of the bracket before installing the shade.
- Position the shade so that the front faces you.
- Slide the headrail into the installation brackets so the headrail is between the lever and the bracket, as shown.
- Firmly push the headrail into each bracket until it clicks and the lever snaps to the right side of the bracket.

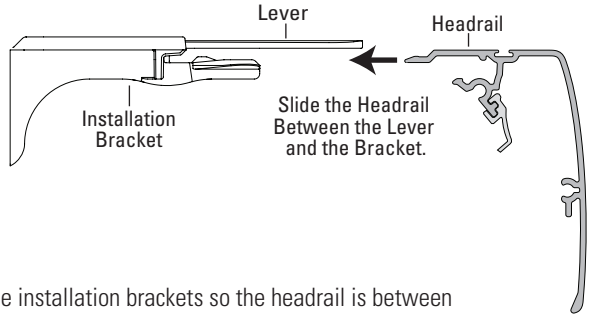

IMPORTANT: Carefully pull on the headrail at each bracket to ensure it is installed securely.

Attach the Dust Cover (Optional for Outside Mounts)

The dust cover is used to protect the top of the headrail from exposure on outside mounted shades.

- Cut the dust cover to desired width.
- Remove the paper backing on one side of the hook and loop fastener dots.
- Apply the dots to the installation brackets on each end of the shades.

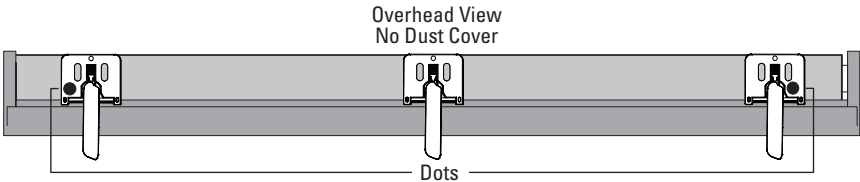

- Remove the remaining paper backing from the dots.
- Center the dust cover over the top of the shade, above the dots.
- Press the dust cover down onto the dots.

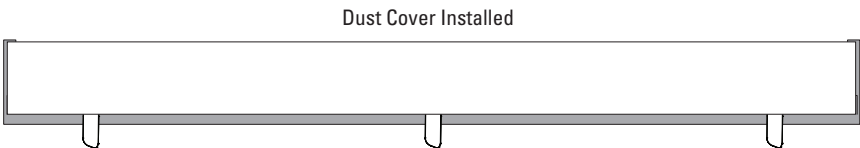

Attach the Magnetic Hold-Down Brackets (Optional)

- Lower the shade.
- Place the magnetic hold-down bracket onto the bottom rail just inside the end cap, oriented as shown.
- Mark the screw location using the mounting options shown below.
 - The screw should be placed in the middle of the channel. This will allow for adjustment.

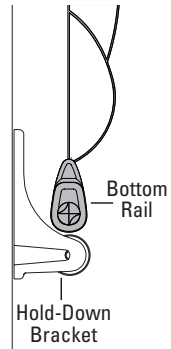

Outside Mount



Preferred



Alternate

Inside Mount



Preferred



Alternate

- Drill the screw holes using a $\frac{3}{32}$ " drill bit.
- Attach the hold-down brackets to the mounting surface using the screws provided.
- If necessary, adjust bracket height by loosening the screw and sliding the bracket up or down.

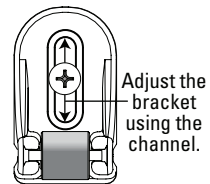

OPERATION

Operate the Shade

For better support and smoother operation, hold the bottom rail at the center when raising and lowering the shade.

To Lower the Shade

- Slowly and steadily pull down on the bottom rail or optional handle.

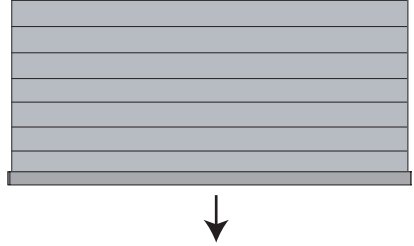

To Raise the Shade

- Slowly and steadily push up on the bottom rail or optional handle.

IMPORTANT: When raising the shade, be sure to raise it straight up. Pushing it up to the left or right will make the fabric skew. If the fabric skews into the headrail, it can prevent the shade from operating and possibly fray the fabric edges.



Troubleshooting

Problem	The shade will not fit into the installation brackets.
Solution	<p>Check that the installation brackets are aligned and level. Adjust and/or shim to level, if necessary.</p> <p>Be sure the heads of the mounting screws are flush against the installation bracket.</p> <p>Check that the headrail is completely inserted into the installation brackets. The lever should snap to the right side of the bracket to ensure proper installation. See "Install the Shade" on page 8.</p>
Problem	The shade does not roll up, or it rolls up too slowly.
Solution	<p>If the hold down brackets have been used, make sure they have been released.</p> <p>Check that the shade is being raised straight up and is not skewing the fabric against the headrail. If this is not the case, you can adjust by:</p> <p>Adding Spring Tension</p> <ul style="list-style-type: none"> ■ Locate the adjustment behind the left end cap cover. <ul style="list-style-type: none"> ➤ The cover is removed by placing your thumb in the center and releasing the snap on the top back corner. ■ Raise the shade completely and hold into place. ■ Push a $\frac{3}{16}$" Allen wrench into the access hole in the end cap of the shade (at least a $\frac{1}{2}$"). <p>CAUTION: When pushing the Allen wrench into the access hole, you are compressing a spring and freeing the lock from engagement.</p> <ul style="list-style-type: none"> ■ Using one-half turn increments, rotate the Allen wrench counter-clockwise to add spring tension. Test and repeat, if necessary. ■ To re-engage the lock, simply pull the Allen wrench straight out of the access hole.

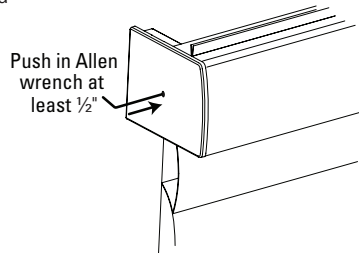

OPERATION

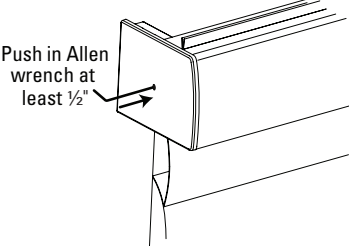
Problem	The shade will drift up once stopped.
Solution	<p>Removing Spring Tension</p> <ul style="list-style-type: none">■ Locate the adjustment behind the left end cap cover.<ul style="list-style-type: none">➤ The cover is removed by placing your thumb in the center and releasing the snap on the top back corner.■ Raise the shade completely and hold into place.■ Push a $\frac{3}{16}$" Allen wrench into the access hole in the end cap of the shade (at least a $\frac{1}{2}$").<p>CAUTION: When pushing the Allen wrench into the access hole, you are compressing a spring and freeing the lock from engagement.</p>■ Using one-half turn increments, rotate the Allen wrench clockwise to remove spring tension. Test and repeat, if necessary.■ To re-engage the lock, simply pull the Allen wrench straight out of the access hole. 
Problem	The shade is hard to raise or lower, or will not raise or lower.
Solution	<p>Shades cannot be forced into tight inside mount window openings. If an inside mount, make sure there is clearance between the ends of the shade and the window casement.</p> <p>Check that the installation brackets are level. Shim to level, if necessary.</p>
Problem	Cells do not align on side-by-side shades.
Solution	<p>Cell alignment is guaranteed within $\frac{1}{8}$" when shades are ordered at the same time, at the same height, with the same color and fabric, and when specified on the order form.</p> <p>Check that the windows are square and the same height.</p>

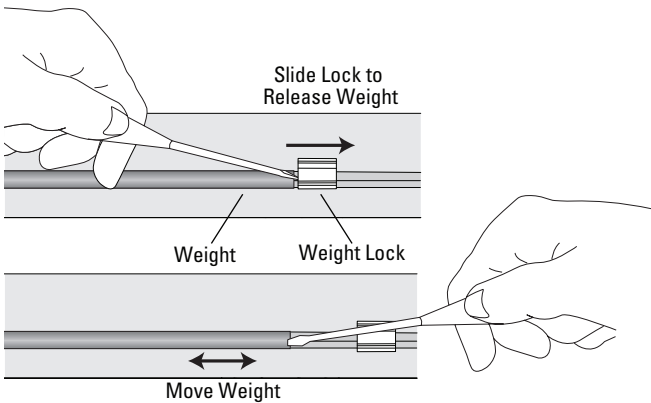
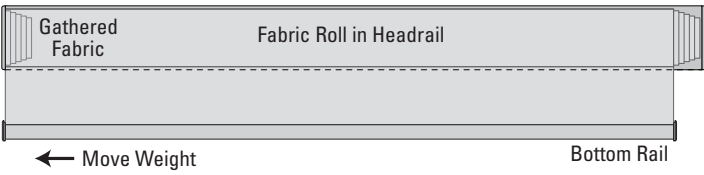
<p>Problem</p>	<p>The shade raises or lowers unevenly, the bottom rail is not level when fully raised, or the fabric winds unevenly or starts to rub against one end of the headrail.</p>
<p>Solution</p>	<p>Keep the bottom rail level while raising the shade. Side-to-side movement while raising the shade may cause fabric to skew.</p> <p>Check that the window is square by measuring the diagonals.</p> <p>Check that the installation brackets are level. Shim to level, if necessary.</p> <p>If the headrail is level and the window is square, adjust the bottom rail weight.</p> <p>Adjusting the Bottom Rail Weight</p> <p>IMPORTANT: Only adjust the bottom rail weight if the fabric does not roll up straight into the headrail.</p> <p>First, release both weight locks. On the back of the bottom rail, insert a flat blade screwdriver into the slot in each weight lock and slide them away from the weight.</p> <p>Slide the weight, in 1" increments, in the direction the fabric is gathering.</p>  <p>Secure the weight by sliding each lock back in position next to the weight.</p>  <p>Test and adjust again, if necessary.</p>

CARE

Removing the Shade

- Fully raise the shade.
- Move each lever of the installation brackets to the left to release the shade.
 - A flat blade screwdriver can be used to move the lever.

CAUTION: Be very careful not to tear or damage the fabric.

- If the lever is inaccessible or inoperable, lower the shade until you can see the underside of the bracket. Carefully reach a small flat blade screwdriver behind the shade to the tab on bottom of the bracket between the screw holes.
 - Push the tab away from the shade and pull the headrail forward to release it from the bracket.
- Carefully pull the shade away from the brackets to remove it.

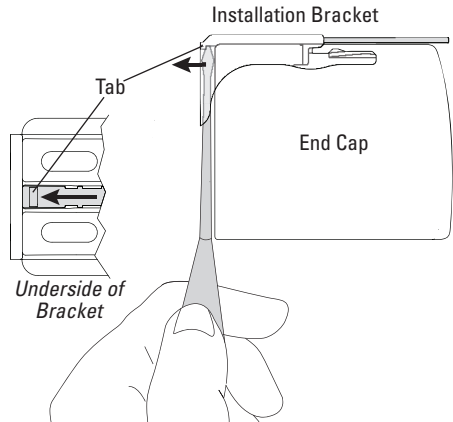
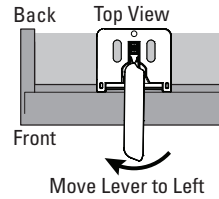

Cleaning Procedures

Sonnette™ cellular roller shades are made from anti-static, dust-resistant materials which repel dirt and dust. The following options are available if your shade needs cleaning.

CAUTION: Do not steam the shades.

Dusting

- Regular light dusting with a feather duster is all the cleaning needed in most circumstances.

Vacuuming

- Use a hand-held vacuum with low suction for more thorough dust removal.

Compressed Air

- Use compressed air to blow dust and dirt off shades.

Spot-Cleaning

CAUTION: Do not use spot clean treatment on Highline™, Textura™, and Elan® Metallic fabrics.

- Prepare a solution of warm water and a mild detergent.
- Dampen a clean cloth in the solution and wring it out.
- Dab the spot with the dampened cloth until it is removed. Do not rub the fabric.
- Allow the shade to dry in the completely lowered position.

Bathtub Cleaning/Water Immersion

CAUTION: Do not immerse the hardware, Elan Metallic, or room-darkening fabrics.

- Immerse the shade in a basin or bathtub filled with warm water and a mild detergent.

IMPORTANT: Never immerse the headrail into the solution.

- Rinse with clean water.
- Before removing from the rinse water, fully raise the shade and tilt it to allow excess water to drain off.
- Dry the shade completely in the lowered position.

Injection/Extraction Cleaning

CAUTION: Do not use injection/extraction cleaning on Elan Metallic fabrics.

This type of professional cleaning injects a cleaning solution into the fabric and extracts the dirty solution in the same motion.

A Note About Sonnette™ Fabrics

As with all textiles, Sonnette™ fabric is subject to some variation. Slight wrinkling, puckering, or bowing is inherent to this textile product and should be considered normal, acceptable quality. These characteristics are not usually visible from the front or rear but may be visible from a side angle.

LIFETIME GUARANTEE

The Hunter Douglas® Lifetime Guarantee is an expression of our desire to provide a thoroughly satisfying experience when selecting, purchasing and living with your window fashion products. If you are not thoroughly satisfied, simply contact Hunter Douglas at (888) 501-8364 or visit hunterdouglas.com. In support of this policy of consumer satisfaction, we offer our Lifetime Limited Warranty as described below.

COVERED

BY A LIFETIME LIMITED WARRANTY

- Hunter Douglas window fashion products are covered for defects in materials, workmanship or failure to operate for as long as the original retail purchaser owns the product (unless shorter periods are provided below).
- All internal mechanisms.
- Components and brackets.
- Fabric delamination.
- Operational cords for a full 7 years from the date of purchase.
- Repairs and/or replacements will be made with like or similar parts or products.
- Hunter Douglas motorization components are covered for 5 years from the date of purchase.

Hunter Douglas (or its licensed fabricator/distributor) will repair or replace the window fashion product or components found to be defective.

NOT COVERED

BY A LIFETIME LIMITED WARRANTY

- Any conditions caused by normal wear and tear.
- Abuse, accidents, misuse or alterations to the product.
- Exposure to the elements (sun damage, wind, water/moisture) and discoloration or fading over time.
- Failure to follow our instructions with respect to measurement, proper installation, cleaning or maintenance.
- Shipping charges, cost of removal and reinstallation.

TO OBTAIN WARRANTY SERVICE

1. Contact your original dealer (place of purchase) for warranty assistance.
2. Visit hunterdouglas.com for additional warranty information, frequently asked questions and access to service locations.
3. Contact Hunter Douglas at (888) 501-8364 for technical support, certain parts free of charge, for assistance in obtaining warranty service or for further explanation of our warranty.

NOTE: In no event shall Hunter Douglas or its licensed fabricators/distributors be liable or responsible for incidental or consequential damages or for any other indirect damage, loss, cost or expense. Some states do not allow the exclusion or limitation of incidental or consequential damages, so the above exclusion or limitation may not apply to you. This warranty gives you specific legal rights, and you may also have other rights which vary from state to state.

Different warranty periods and terms apply for commercial products and applications.

HunterDouglas



hunterdouglas.com

